

## DESIGN CONSIDERATIONS

The Victaulic piping method may be used for joining a variety of piping systems for a wide variety of services. It may be utilized for varied pipe sizes, pipe materials and wall thickness. Products are available to provide rigid or flexible systems. For specific product information relating to use on varied pipe materials refer to the appropriate sections of this catalog.

As with any piping method, the nature of the method should be considered in designing the piping systems. This design data applies primarily to grooved end pipe, however, much of the information applies to other Victaulic mechanical piping products used in conjunction with grooved components.

The material presented is intended solely for piping design reference in utilization of Victaulic products for their intended application. It is not intended as a replacement for competent, professional assistance which is an obvious requisite to any specific application. Good piping practice should always prevail. Specific pressures, temperatures, external or internal loads, performance standards and tolerances must never be exceeded.

**While every effort has been made to ensure its accuracy, Victaulic Company of America, its subsidiaries and affiliated companies, make no express or implied warranty of merchantability or fitness for a particular purpose respecting the information contained in this Catalog or the materials referred to therein. Illustrations shown within this catalog are for illustrative purposes. They are not drawn to scale and may have been exaggerated for clarity. Anyone making use of the information or material contained herein does so at his own risk and assumes any and all liability resulting from such use.**

## RIGID COUPLINGS

Rigid grooved end piping systems (including Styles 07, 307, HP-70, 005, and others) provide a mechanical and frictional interlock onto the pipe ends sufficient to result in a rigid joint.

HP-70 rigid couplings grip the base of the groove providing a rigid joint.

Style 07, Zero-Flex® couplings have a unique, patented angle pad design which constricts the housing keys into the groove around the full circumference to grip the pipe rigidly. The housings slide on the angled pads rather than mating squarely.

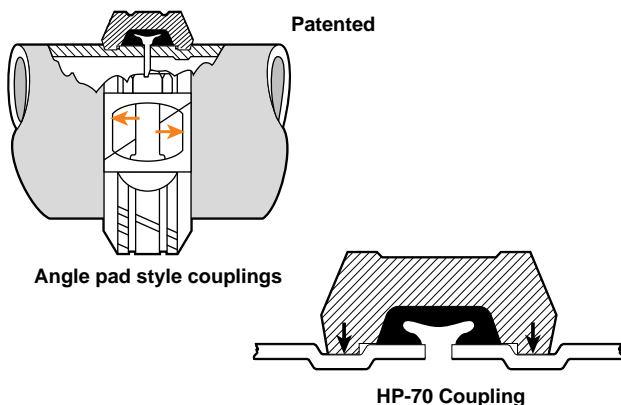

This sliding adjustment also forces the key sections into opposed contact on the inside and outside groove edges, pushing the joint to its maximum pipe end separation during assembly.

These products can be considered to have system behavior characteristics similar to those of welded or flanged systems, in that all piping remains in strict alignment and is not subject to deflections during operation. For this reason, these products require support techniques identical to those used in traditional flanged or welded systems.

## FLEXIBLE COUPLINGS

The following factors must be considered when designing or installing flexible grooved end piping systems (including Styles 75, 77, and others).

### PRESSURE THRUST

When a flexible grooved type mechanical coupling is sustaining forces trying to separate the pipe ends, the shoulder of the groove is pulled hard against the inside face of the coupling key. This is what prevents the pipes from separating.

The allowable force which a joint can sustain varies for different types of couplings, pipe wall thickness, types of pipes and grooving. The product data under the column "Maximum Permissible End Load" shows the maximum allowable end force that different couplings will sustain.

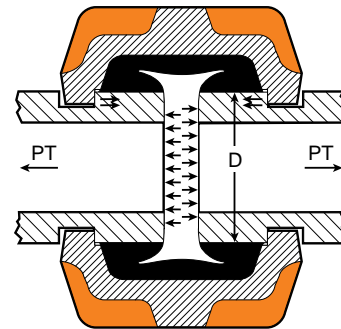

When this end force is due to a closed end or change in direction, the pressure thrust transmitted by the joint can be computed from the formula:

$$PT = \frac{\pi}{4} D^2 p$$

Where:

- PT = Pressure thrust or end load (lbs.)
- D = Outside diameter of pipe (inches)
- p = Internal pressure (PSI)

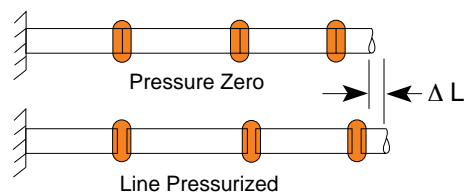

Pipe will be moved to the full extent of the available pipe end gaps when allowed to float. Ensure resulting movement of randomly installed systems is not harmful to joints at changes in directions or branch connections or to parts of structure or other equipment. Note also that thermal expansion of pipes will add to total movement in these cases.

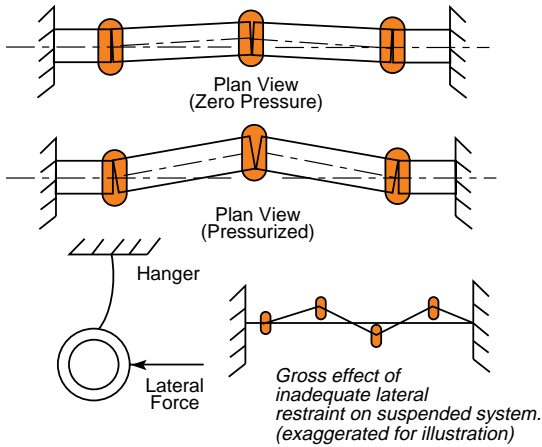

For anchored systems, where pressure thrusts do not act to hold the joints in tension, or in systems where the joints have been intentionally deflected (e.g., curves), provide lateral restraint to prevent movement of the pipes due to pressure thrusts acting at deflections. Lightweight hangers are not adequate in preventing sideways movement of pipes. It should be anticipated that small deflections will occur in all straight lines and side thrusts will be exerted on the joints.

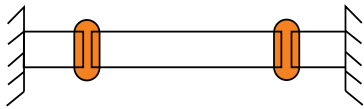

Angular deflection at butted or fully spaced joints is not possible unless the ends of the pipes can shorten and grow as required.

Unrestrained deflected joints will straighten up under the action of axial pressure thrusts or other forces acting to pull pipes apart. If joints are to be maintained deflected, then lines must be anchored to restrain pressure thrusts and end pull forces, otherwise sufficient lateral force must be exerted to keep joint deflected.

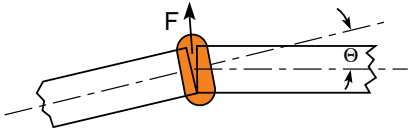

Lateral forces ( $F$ ) will always act on deflected joints due to internal pressure. A fully deflected joint will no longer be capable of providing the full linear movement normally available at the joint.

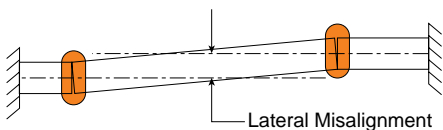

At least two flexible couplings are required to provide for lateral misalignment of pipes. Angular deflection of each joint must not exceed Maximum Deflection From Centerline published for each Victaulic coupling style.

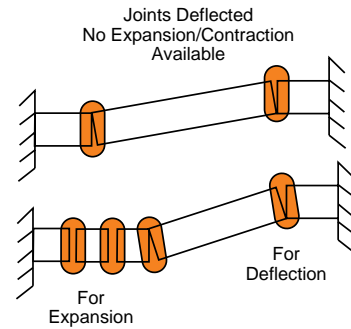

The grooved piping method will not allow both maximum linear movement and maximum angular movement simultaneously at the same joint. If both are expected simultaneously, systems should be designed with sufficient joints to accommodate both, including allowance for recommended tolerances.

Flexible couplings do not automatically provide for expansion or contraction of piping. Always consider best setting for pipe end gaps. In anchored systems, gaps must be set to handle combinations of expansion and contraction. In free floating systems offsets of sufficient length must be used to accommodate movement without overdeflecting joints.

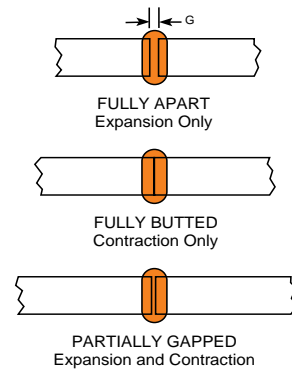

Linear movement available at flexible grooved pipe joints is published under performance data for each Victaulic coupling style. These values are MAXIMUMS. For design and installation purposes, these figures should be reduced by the following factors to allow for pipe groove tolerances.

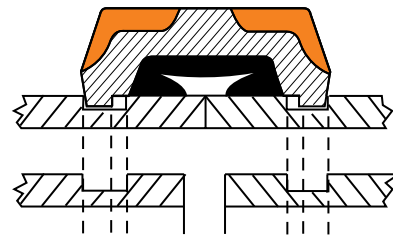

**LINEAR MOVEMENT TOLERANCE**

- 3/4 - 3 1/2" (20 - 90 mm) – Reduce published figures by 50%
  - 4" (100 mm) and larger – Reduce published figures by 25%
- Standard roll grooved pipe will provide one-half the expansion/contraction or deflection capabilities of the same size standard cut groove pipe.

## OFFSETS AND BRANCH CONNECTIONS

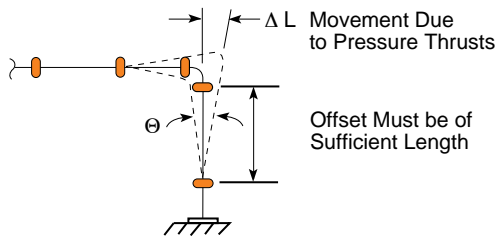

Ensure that branch connections and offsets are sufficiently long that maximum angular deflection of coupling (shown in Performance Data for each coupling style) is never exceeded and can accommodate anticipated total movement of pipes.

Otherwise, anchor system to direct movement away from these. Also ensure that adjacent pipes can move freely to provide anticipated movements. (Refer to page 6 for more details.)

## ANGULAR DEFLECTIONS

Angular deflection available at flexible grooved pipe joints is published under Performance Data for each Victaulic coupling style. These values are MAXIMUMS. For design and installation purposes these figures should be reduced by the following factors to allow for pipe grooving tolerances.

Θ = Maximum angular deflection between center lines as shown under Performance Data.

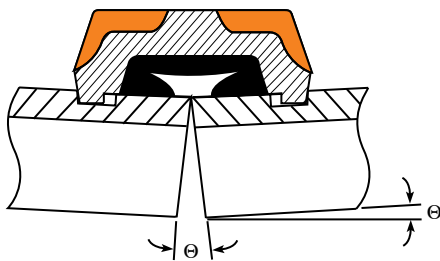

ANGULAR MOVEMENT TOLERANCE

¾ - 3½" (20 - 90 mm) – Reduce published figures by 50%  
4" (100 mm) and larger – Reduce published figures by 25%

Standard cut grooved pipe will provide double the expansion/contraction or deflection capabilities of the same size standard roll groove pipe.

Standard roll grooved pipe will provide one-half the expansion/contraction or deflection capabilities of the same size standard cut groove pipe.

The angular deflection available at a Victaulic flexible grooved pipe joint is useful in simplifying and speeding installation.

NOTE: Joints which are fully deflected can no longer provide linear movement. Partially deflected joints will provide some portion of linear movement. NOTE: Pressure thrusts will tend to straighten deflected pipe.

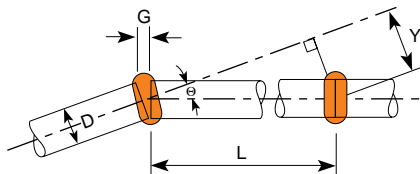

$$Y = L \sin \Theta$$

$$\Theta = \sin^{-1} \frac{G}{D}$$

$$Y = \frac{G \times L}{D}$$

## Where:

Y = Misalignment (Inches)

G = Maximum Allowable Pipe End Movement (Inches) as shown under Performance Data (Published value to be reduced by Design Tolerance.)

Θ = Maximum Deflection (Degrees) from Center Line as shown under Performance Data (Published value to be reduced by Design Tolerance.)

D = Pipe Outside Diameter (Inches)

L = Pipe Length (Inches)

## MISALIGNMENT

Pipe misalignment can be accommodated with a Victaulic flexible grooved piping system. Note that at least two flexible couplings must be used for the combined lateral displacement and angular deflection (Y). (Refer to 26.03 for details.)

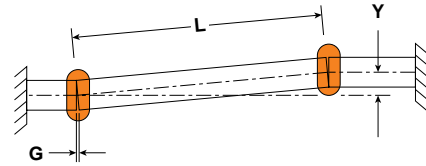

The movement available can be calculated from the flexible coupling Performance Data.

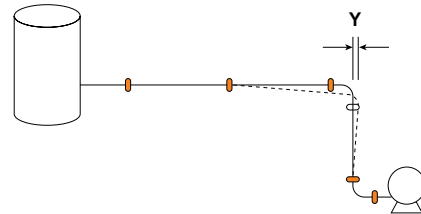

## CURVE LAYOUT

Curves may be laid out with straight pipe lengths utilizing the angular deflection (under performance data) available at each flexible coupling. Note that if the maximum angle of deflection at the couplings is used to lay the curve, no allowance is left for expansion/contraction.

NOTE: Pressure thrusts will tend to straighten the curve. Consideration must be given to proper anchoring.

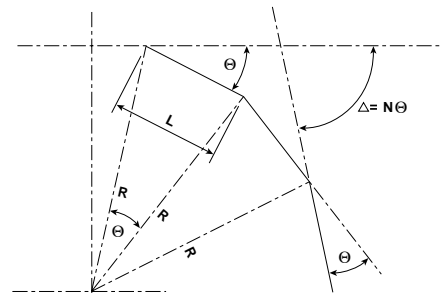

$$R = \frac{L}{2 \sin \frac{\Theta}{2}}$$

$$L = 2 R \sin \frac{\Theta}{2}$$

$$N = \frac{\Delta}{\Theta}$$

## Where:

N = Number of Couplings

R = Radius of Curve (Feet)

L = Pipe Length (Feet)

Θ = Deflection from Centerline (°) of each Coupling (See Data Sheets – Published value to be reduced by Design Tolerance)

Δ = Combined Angular Deflection of all couplings

For curves of less than 90° total deflection, the data shown on the previous page can be used to determine:



1. The radius of curve that can be laid using pipes of a given length and utilizing either the full or partial angle of deflection available from the couplings used. Alternatively, the maximum length of pipe that can be used to negotiate a curve of a certain radius using either the maximum or partial angle of deflection available from the couplings.
2. The total number of flexible couplings required to negotiate a curve having a given deflection angle.

## PIPE SUPPORT ANCHORAGE AND GUIDANCE

### FLEXIBLE COUPLINGS – RIGID COUPLINGS

When designing anchorage, support and guidance systems for piping joined with flexible or rigid mechanical grooved type couplings, it is necessary to give consideration to certain characteristics of these couplings. These characteristics distinguish flexible grooved type couplings from other types and methods of pipe joining. When this is understood, the designer can utilize the many advantages that these coupling provide.

Coupling Key:

-  = Rigid Coupling
-  = Flexible Coupling

### USE OF HANGERS AND SUPPORTS

The use of hangers and supports offering freedom of movement in one or more directions has to be considered to allow pipes to move freely. Spring hangers are good practice at change of direction to allow freedom of pipe movement.

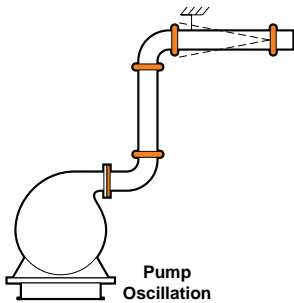

### ACCOMMODATING COUPLING FLEXIBILITY

Flexible grooved type couplings allow angular flexibility and rotational movement to take place at joints. These features provide advantages in installing and engineering piping systems, but must be considered when determining hanger and support spacing.

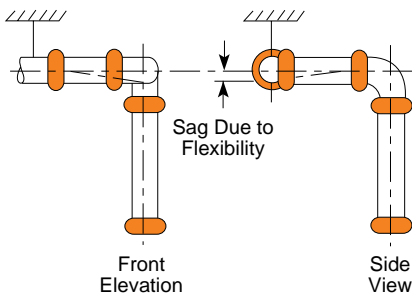

As illustrated, it is obvious that this system would require further hangers to eliminate the drooping of the pipes that would occur. Hanger positions must therefore be considered in relation to the angular and rotational movement that will occur at joints.

Good use can be made of rigid Zero-Flex Style 07 couplings in boiler and machinery rooms. These will increase rigidity where needed.

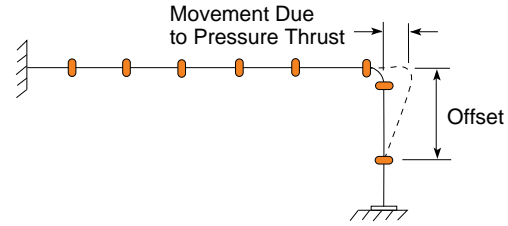

In the system illustrated, if the joints had all been installed butted or only partially open when pressurized, the pipe ends would all move to the maximum extent allowed by the coupling and this movement would all accumulate at the end of the system. The offset would have to be capable of deflecting sufficiently, otherwise harmful bending moments would be induced in the joints of the offset. Note, if the pipes were to expand due to thermal changes, then further growth of the pipes would also take place at the ends.

### ANCHORAGE AND SUPPORT

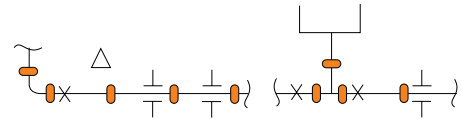

Ensure anchorage and support is adequate. Use anchors to direct movement away from or to protect critical changes in direction, branch connections and structure. Spacing and types of supports should consider anticipated pipe movements.

If rigid couplings are used, consideration must be given to use of expansion joints if thermal movement is expected.

### RULES APPLICABLE TO LONG RUNS OF PIPE

For long pipe runs it is normal practice to anchor or block all changes of directions to prevent pressure thrusts from opening up flexible joints and causing gross movement of the pipes away from the changes in direction. Intermediate anchors could prevent accumulation of end pull forces on the joints due to thermal shunting of the pipes. Where changes in direction of piping inside a structure (e.g., pump house) can create pressure thrusts, a major anchor could be used to prevent pipe being pulled into the pump house. This anchor will also prevent harmful thermal movement of pipe.

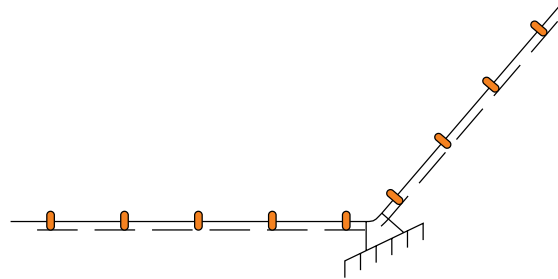

Where lines are likely to block or plug, joints and in anchors (including intermediate anchors) should be designed to withstand the longitudinal pressure thrust or End Load created by the blockage.

# PIPE SUPPORT

## FLEXIBLE COUPLINGS – RIGID COUPLINGS

Piping joined with grooved type couplings, like all other piping systems, requires support to carry the weight of pipes and equipment. Like all other methods of joining pipes, the support or hanging method must be such as to eliminate undue stresses on joints, piping and other components. Additionally, the method of support must be such as to allow movement of the pipes where required and to provide for other special requirements such as drainage, etc. as may be required by the designer. The support system for flexible mechanical grooved type pipe couplings must consider some of the special requirements of these couplings.

The tables show suggested maximum span between pipe supports for horizontal straight runs of standard weight steel pipe carrying water or similar liquids. They are not intended to be used as specifications for all installations. These DO NOT apply where critical calculations are made or where there are concentrated loads between supports.

## RIGID SYSTEMS

For Victaulic rigid coupling Styles 07, 307, HP-70, 005, and others, the Maximum Hanger Spacing below may be used.

26.01-1A

Nominal Pipe Size Inches millimeters	Suggested Maximum Span Between Supports Feet/meters					
	Water Service			Gas or Air Service		
	*	†	‡	*	†	‡
1 25	7 2.1	9 2.7	12 3.7	9 2.7	9 2.7	12 3.7
1¼ 32	7 2.1	11 3.4	12 3.7	9 2.7	11 3.4	12 3.7
1½ 40	7 2.1	12 3.7	15 4.6	9 2.7	13 4.0	15 4.6
2 50	10 3.1	13 4.0	15 4.6	13 4.0	15 4.6	15 4.6
3 80	12 3.7	15 4.6	15 4.6	15 4.6	17 5.2	15 4.6
4 100	14 4.3	17 5.2	15 4.6	17 5.2	21 6.4	15 4.6
6 150	17 5.2	20 6.1	15 4.6	21 6.4	25 7.6	15 4.6
8 200	19 5.8	21 6.4	15 4.6	24 7.3	28 8.5	15 4.6
10 250	19 5.8	21 6.4	15 4.6	24 7.3	31 9.5	15 4.6
12 300	23 7.0	21 6.4	15 4.6	30 9.1	33 10.1	15 4.6
14 350	23 7.0	21 6.4	15 4.6	30 9.1	33 10.1	15 4.6
16 400	27 8.2	21 6.4	15 4.6	35 10.7	33 10.1	15 4.6
18 450	27 8.2	21 6.4	15 4.6	35 10.7	33 10.1	15 4.6
20 500	30 9.1	21 6.4	15 4.6	39 11.9	33 10.1	15 4.6
24 600	32 9.8	21 6.4	15 4.6	42 12.8	33 10.1	15 4.6

\* Spacing corresponds to ANSI B31.1 Power Piping Code.

† Spacing corresponds to ANSI B31.9 Building Services Piping Code.

‡ Spacing corresponds to NFPA 13 Sprinkler Systems.

## FLEXIBLE SYSTEMS

For coupling Styles including 75, 77, and others. Standard grooved-type couplings allow angular, linear and rotational movement at each joint, to accommodate expansion, contraction, settling, vibration, noise and other piping system movement. These features provide advantages in designing piping systems but must be considered when determining hanger and support bracing and location.

### Maximum Hanger Spacing

For straight runs without concentrated loads and where full linear movement is required.

26.01-2A

Nominal Pipe Size In./mm	Pipe Length in Feet/meters									
	7 2.1	10 3.0	12 3.7	15 4.6	20 6.1	22 6.7	25 7.6	30 9.1	35 10.7	40 12.2
	*Average Hangers per Pipe Length Evenly Spaced									
¾ - 1 20 - 25	1	2	2	2	3	3	4	4	5	6
1¼ - 2 32 - 50	1	2	2	2	3	3	4	4	5	5
2½ - 4 65 - 100	1	1	2	2	2	2	2	3	4	4
5 - 8 125 - 200	1	1	1	2	2	2	2	3	3	3
10 - 12 250 - 300	1	1	1	2	2	2	2	3	3	3
14 - 16 350 - 400	1	1	1	2	2	2	2	3	3	3
18 - 24 450 - 600	1	1	1	2	2	2	2	3	3	3
28 - 42 700 - 1050	1	1	1	1	2	2	2	3	3	3

\*No pipe length should be left unsupported between any two couplings.

### Maximum Hanger Spacing

For straight runs without concentrated loads and where full linear movement is not required.

26.01-3A

Nominal Pipe Size Range Inches/millimeters	Suggested Maximum Span Between Supports Feet/meters
¾ - 1 20 - 25	8 2.4
1¼ - 2 32 - 50	10 3.0
2½ - 4 65 - 100	12 3.7
5 - 8 125 - 200	14 4.3
10 - 12 250 - 300	16 4.9
14 - 16 350 - 400	18 5.5
18 - 30 450 - 750	20 6.1
32 - 42 800 - 1050	21 6.4

# ANCHORS

## FLEXIBLE COUPLINGS – RIGID COUPLINGS

Anchors can be used to prevent movement due to pressure thrust.

There are two types of anchors which are commonly used:

- A. Main anchors
- B. Intermediate anchors

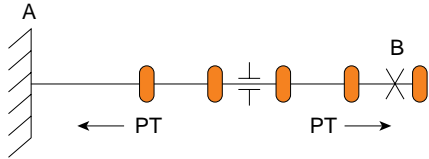

### A. MAIN ANCHORS

Main anchors are installed at or near terminations and changes of direction of a pipe line. The forces acting on a main anchor will result from internal pressure thrust. These forces can generate substantial loads which may require structural analysis.

PT = Pressure Thrust (Pounds)  
 D = Outside Diameter of Pipe (Inches)  
 p = Internal Pressure (PSI)

$$PT = \frac{\pi}{4} D^2 p$$

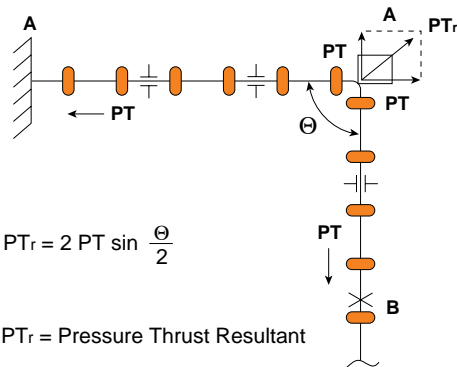

$$PT_r = 2 PT \sin \frac{\theta}{2}$$

PT<sub>r</sub> = Pressure Thrust Resultant

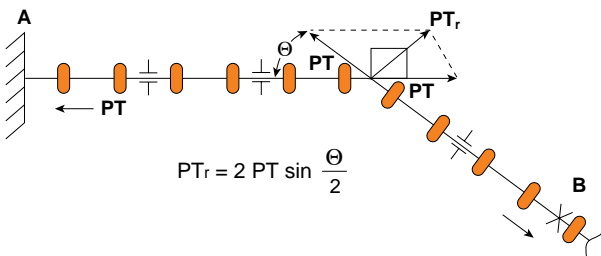

$$PT_r = 2 PT \sin \frac{\theta}{2}$$

### B. INTERMEDIATE ANCHORS

Intermediate anchors divide a long pipe run, with main anchors at each end, into individual expanding sections. The pressure thrust on the intermediate anchors cancel each other out.

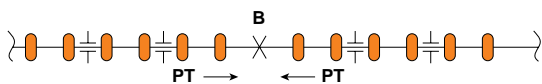

Where there is a change in pipe diameter, there will be a differential pressure thrust acting on an intermediate anchor.

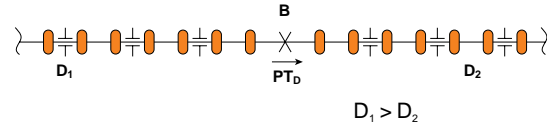

The differential pressure thrust  $PT_D$  is calculated by:

$$PT_D = p \left( \frac{\pi D_1^2}{4} - \frac{\pi D_2^2}{4} \right)$$

To keep pipe in alignment, guidance to prevent lateral movement or deflection at flexible coupling joints may be required. An alternative would be to use rigid couplings to keep joints from deflecting where not desired.

## APPLICATIONS

The following are shown to call attention to the mechanical advantages of the grooved piping method; how they can be utilized to the piping systems designer's benefit. These are presented to stimulate thought and should not be considered as recommendations for a specific system.

The Victaulic grooved piping method, when used in a piping system, should always be utilized in designs consistent with good piping practice. The design considerations for engineering and installing grooved piping systems covered elsewhere in this manual should always be referred to.

### THERMAL EXPANSION AND/OR CONTRACTION

Movement in piping systems due to thermal changes can be accommodated with the grooved piping method. Sufficient flexible joints must be available to accommodate anticipated movement, including Movement Tolerance. If anticipated movement will be greater than provided by the total number of joints in the system, additional expansion in the form of a Victaulic Style 150 or 155 expansion joint (see separate literature) must be provided. Rigid systems will necessitate use of expansion joints on flexible couplings at offsets where system movement is required.

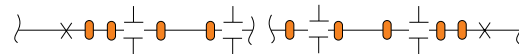

Example 1

#### Example 1:

400 foot (122 m) long, straight piping system; 6" (150 mm); 20 foot (6.1 m) random lengths; installed at 60°F (15.5°C) (also lowest operating temperature); maximum operating temperature of 180°F (82.2°C). Standard expansion tables show this system will give 3.7" (94 mm) total anticipated movement.

20 . . . . .	Joints between anchor points
X 1/4" (6.4 mm) . . . . .	Movement per cplg. (Style 77 on cut grooved pipe)
5" (128 mm) . . . . .	Available movement
-25% . . . . .	Movement tolerance (see Section 27.02)
3.75" (96 mm) . . . . .	Adjusted available movement

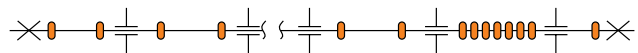

Example 2

#### Example 2:

Same as above. Installed at 20°F (-6.7°C) and operating at 200°F (93°C). Anticipated movement = 5.5" (139 mm).

A standard 6" (150 mm) Victaulic Style 150 expansion joint will supply an additional 3" (76.2 mm) of movement required. Refer to separate product literature for details.

In the above example, Style 07 rigid couplings could have been used and the expansion and/or contraction requirement be made up with additional flexible couplings and/or Style 150, 155 expansion joints as needed.

See page 5 for pipe support suggestions.

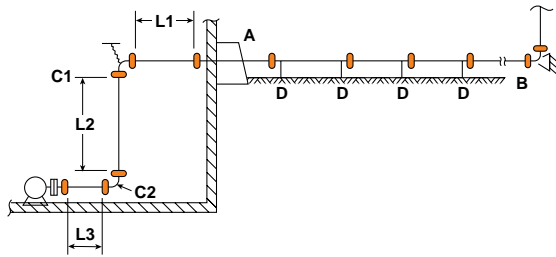

Example 3

**Example 3:**

To properly restrain this system, it would be necessary to provide a pressure thrust anchor at "A" to prevent the piping outside being forced inside by the pressure thrust acting at the elbow "B." Inside, it would be necessary to provide a hanger at point C1, or a base support at point C2. Providing any expected pipe movements, no anchoring would be required and the self-restraining feature of the joints would hold the piping securely together. Outside, it would be necessary to ensure that the maximum end load of the joints was not exceeded due to thermal movement of the pipes. Intermediate anchors may be required. Pipe must be properly supported ("D") and guided. Where flexible couplings are not required, rigid couplings can reduce supports and offsets (except where thermal movement is anticipated).

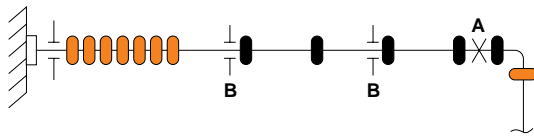

Example 4

**Example 4:**

Anchor at "A" to prevent pressure thrust from moving expansion unit. Provide guides at points "B" to direct movement into expansion joint. See page 5 for pipe support suggestions.

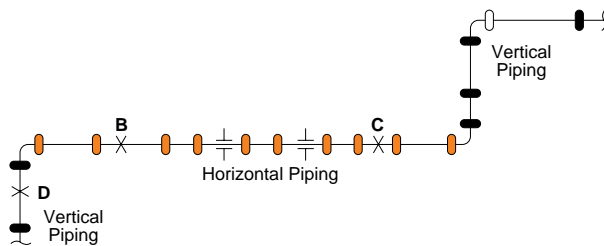

Example 5

**Example 5:**

Anchor at "A" and "D" to support weight of pipe. Use hangers to support weight of piping. Anchors may be required at "B" and "C" as well as guides, if flexible couplings are used as expansion joints.

## ANCHORAGE AND SUPPORT OF VERTICAL PIPES

A number of methods of installing vertical piping systems may be considered:

### VICTAULIC FLEXIBLE SYSTEM

Risers are commonly installed with anchors at the base and riser top with the piping in between guided at every other floor to prevent "snaking" of the line. Pre-gapping of the pipe ends will allow for thermal expansion up to the maximum published in our literature. Risers with branch connections should have intermediate anchors or offsets to prevent system movement at these locations which could cause shearing of components or branches.

### VICTAULIC RIGID SYSTEM

Risers consisting entirely of rigid couplings can get treated similar to welded systems and, where thermal movement is required, expansion joints or offsets will be necessary to prevent system movement and damage to components. These systems are obviously most advantageous where rigidity is desired as in mechanical equipment rooms, at pump connections, etc.

### VICTAULIC COMBINATION SYSTEM

By designing risers with the combination system, you can make use of the rigidity of the Style 07 couplings to reduce guiding requirements, and the flexibility of the Style 77 couplings with short nipples or the Style 150 "Mover" expansion joint, to accommodate thermal movement as required.

#### 1. Risers With Supplementary Thermal Compensators

When greater pipe movement is required, the movement at the joints can be supplemented by the use of Victaulic expansion units consisting of a series of short nipples and couplings or Style 155 or Style 150 Mover expansion joints.

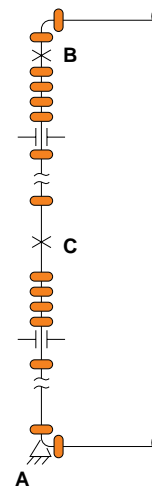

A typical system is illustrated. Adequate guidance must be provided. This system will require pressure thrust anchors at "A" and "B" and also, dependent upon the length of the stack, intermediate anchors such as at "C" to break up the pipe movement and carry some of the total weight if necessary.

When using this method, it is necessary to consider that if pipes are stacked (i.e., end butted) then couplings joining pipes cannot accommodate expansion so that it may be necessary to consider hanging pipes from points "C" and "B." Also, consider movement so that shear forces are not added at any branches.

**2. Treatment of Risers With Branch Connections**

Free moving risers can cause shear forces at branch connections due to pressure thrusts and/or thermal movement. The pipe should be anchored at or near the base with a major pressure thrust anchor "A" capable of supporting the full pressure thrust and local weight of pipe and fluids. Any movement of horizontal pipe at the bottom of the riser must be considered independently with adequate provision for movement.

When flexible couplings are used, the system can be anchored at the top "B" with an anchor capable of withstanding full pressure thrust at the top of the riser plus local weight of pipe. The use of this upper anchor prevents any possibility of closed joints opening under pressure and causing movement at the riser top.

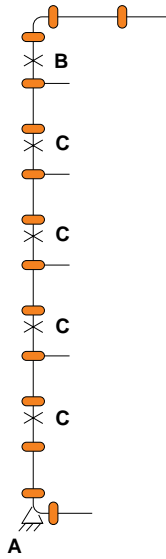

This method is often used for fire standpipe or similar systems where movement would cause shearing of intermediate components or branches.

Piping between upper "B" and lower "A" anchors should be supported by intermediate anchor ("C") capable of supporting local pipe weight and preventing lateral movement. Intermediate clamps should be placed a minimum of every other pipe length.

Proper gapping of pipe to allow adequate thermal movement should be considered depending on nature of movement expected. (Refer to Design Considerations.)

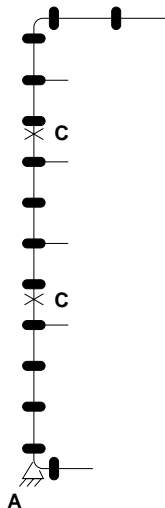

An alternative would be to use rigid couplings which would not allow "closed joints" to open. The system can be anchored at "A" also, and intermediate anchors at "C" can be used to support local pipe weight. Allowance for thermal movement should be considered depending on application.

**3. Treatment of Risers Without Branch Connections for Flexible Couplings**

With this method, a major thrust anchor is again created at the bottom of the stack "A" supports the total weight of pipe and fluids.

Guidance is necessary at suitable intervals to prevent buckling of the riser.

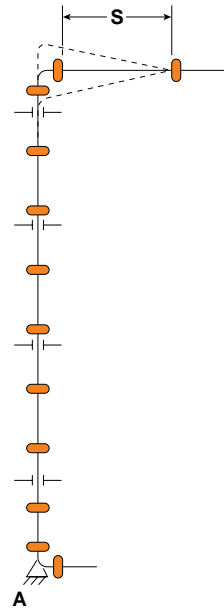

It is necessary that the pipe length "S" at the top of the stack be long enough to accommodate the total vertical movement. This movement is the result of the combined effect of pipe being moved to full extent of the available pipe end gaps due to pressure thrusts and thermal growth.

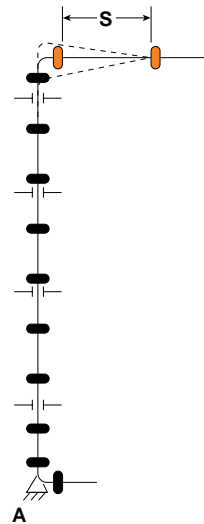

Rigid couplings also could be used to prevent opening of "closed joints." For offset "S" at the top of the stack to accommodate thermal growth, it would be necessary to use the required number of flexible couplings depending on the angular deflection.



#### 4. Treatment of Risers To Eliminate Concentrated Anchor Loads

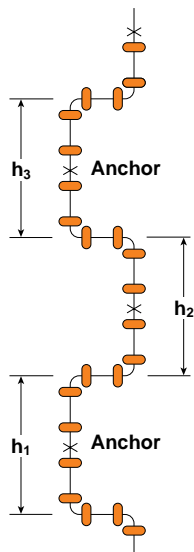

When structural requirements dictate that base anchor load or upper anchor loads must be minimized, then the use of a "looped" system (as shown) should be considered. In the system illustrated, each anchor carries the local weight of pipe.

This method is often considered in tall buildings where high anchor loads would be generated.

The offsets must be long enough to accommodate movement in the pipes due to flexible couplings opening up under pressure plus any thermal or other movements of pipes or supports.

The use of rigid couplings could be considered to prevent joints from opening up and where thermal movement is anticipated, it should be accommodated with the use of flexible couplings or expansion joints.

## SEISMIC APPLICATIONS

The Victaulic system provides many mechanical design features useful in systems subject to earthquake conditions. The inherent flexibility of flexible couplings such as the Style 75 and 77, act to reduce the transmission of stresses throughout the pipe system and the resilient gasket aids to further reduce the transmission of vibration. Where flexibility is not desired, rigid couplings such as the Styles HP-70 and 07 Zero-Flex can be used.

As a general practice, seismic bracing and piping supports are utilized in piping systems to prevent excessive movement during a seismic occurrence which would result in stressing the piping system by controlling and directing system movement. In a similar manner, piping supports for a Victaulic grooved piping system must limit pipe movements such that they do not exceed the recommended allowable deflections and end loads.

An excellent reference source, which covers these piping systems, is NFPA 13 (Installation of Sprinkler Systems). The standard requires sprinkler systems to be protected to minimize or prevent pipe breakage where subject to earthquakes.

This is accomplished by using two techniques:

- a) Making the piping flexible where necessary (Flexible Couplings)
- b) Affixing the piping to the building structure for minimum relative movement (Sway Bracing)

Flexibility is provided by using flexible couplings (e.g., 75, 77) joining grooved end pipe, and swing joints. "Rigid-Type" (e.g., HP-70, 07) mechanical couplings, which do not permit movement at the grooved connection, are not considered flexible couplings. Rigid couplings are used in horizontal piping for purposes other than the requirements of earthquake protection.

Branch lines also braced where movement could damage other equipment.

Where large pipe movements are anticipated, seismic swing joints are made up using flexible grooved couplings, pipe nipples and grooved elbows, as shown on page 10.

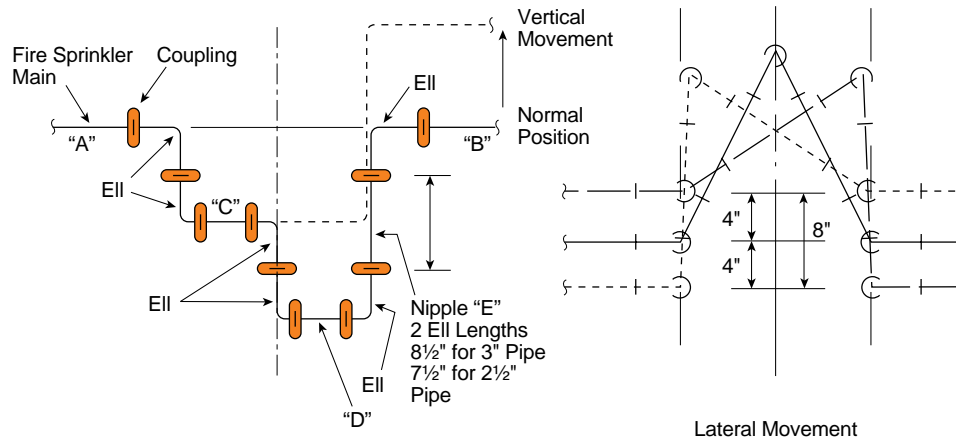
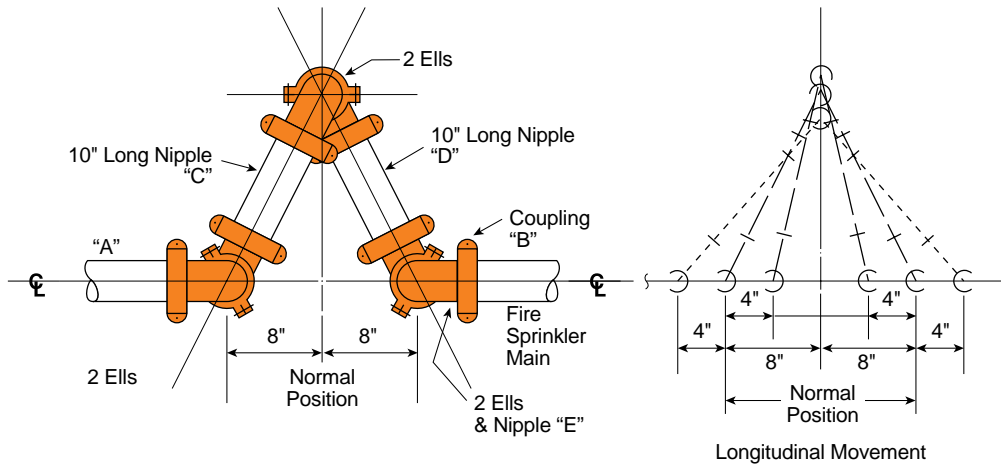
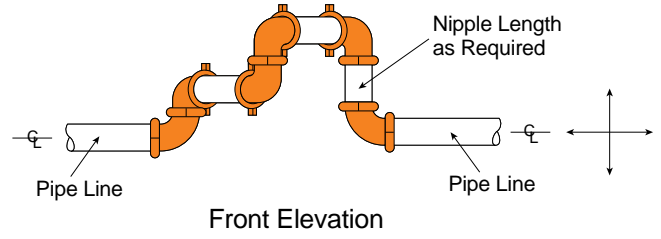
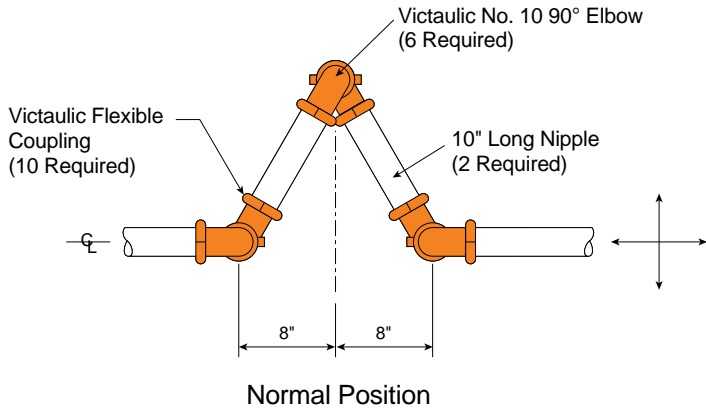

This product shall be manufactured by Victaulic Company. All products shall be installed in accordance with current Victaulic installation/assembly instructions. Victaulic reserves the right to change product specifications, designs and standard equipment without notice and without incurring obligations.