



**Style 07  
Zero-Flex®  
Rigid Coupling  
with Vic-Plus™ Gasket System**

**PRODUCT DESCRIPTION**



Patented

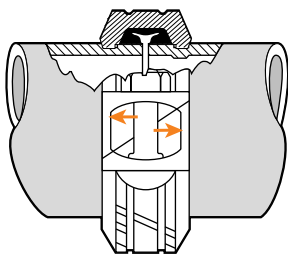

Exaggerated for Clarity

The unique angle-pad design of the Zero-Flex® Style 07 coupling adjusts to standard pipe and roll or cut groove tolerances, positively clamping the pipe to resist flexural and torsional loads. The wider key section fills more of the groove area.

Style 07 couplings are rated up to 750 psi (5175 kPa), dependant on size, for 1 - 24" (25 - 600 mm) piping systems. Style 07 cou-

plings provide rigidity for valve connections, machinery rooms, fire mains, and long straight runs. Support and hanging requirements correspond to ANSI B31.1 Power Piping Code, ANSI B31.9 Building Services Code and NFPA 13 Sprinkler Systems. Angle-pad design permits assembly by removing one nut/bolt and scissoring housing over gasket. This reduces the number of components

to handle during assembly, speeds and eases installation.

**Vic-Plus Gasket System:** Victaulic® now offers a gasket system which requires no field lubrication. The Vic-Plus™ System (patent pending) is dry, clean, and non-toxic. It reduces assembly time substantially and eliminates the mess and chance of over-lubrication.

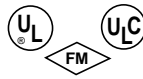

See Victaulic publication 10.01 for details.

**DIMENSIONS**

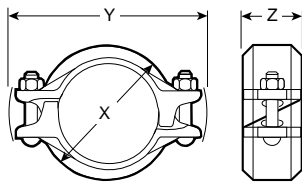

Typical 1 - 12"

Nominal Size Inches mm	Diameter Inches mm	Max. Work Press. PSI* kPa	Max. End Load Lbs.* N	Allow. Pipe End # Sep. In. mm	@ Bolt/Nut No. - Size Inches mm	Dimensions Inches/millimeters			Aprx. Wgt. Each Lbs. kg
						X	Y	Z	
1 25	1.315 33.7	750 5175	650 2890	0.05 1.2	2 - 3/8 X 2	2.36 60	4.22 107	1.84 47	1.6 0.7
1 1/4 32	1.660 42.4	750 5175	1,620 7210	0.05 1.2	2 - 3/8 X 2	2.69 68	4.62 117	1.84 47	1.6 0.7
1 1/2 40	1.900 48.3	750 5175	2,130 9480	0.05 1.2	2 - 3/8 X 2	2.94 75	5.81 148	1.84 47	1.6 0.7
2 50	2.375 60.3	750 5175	3,320 14775	0.07 1.7	2 - 1/2 X 2 1/2	3.35 85	5.78 147	1.84 47	2.3 1.0
2 1/2 65	2.875 73.0	750 5175	4,875 21695	0.07 1.7	2 - 1/2 X 2 3/4	3.88 98	6.38 162	1.84 47	2.6 1.2
76,1 mm	3.000 76,1	750 5175	5,300 23585	0.07 1,7	2 - 12 X 70,0	4.21 107	6.61 168	1.84 47	3.6 1,6
3 80	3.500 88,9	750 5175	7,215 32105	0.07 1,7	2 - 1/2 X 2 1/2	4.54 115	6.81 173	1.84 47	3.0 1,4
4 100	4.500 114,3	750 5175	11,925 53065	0.16 4,1	2 - 1/2 X 2 3/4	5.81 148	8.21 209	2.07 53	5.3 2,4
108,0 mm	4.250 108,0	750 5175	10,635 47325	0.16 4,1	2 - 12 X 70,0	5.56 141	7.98 203	2.07 53	5.2 2,4
5 125	5.563 141,3	750 5175	18,225 81100	0.16 4,1	2 - 5/8 X 3 1/4	7.03 179	9.89 251	2.07 53	7.4 3,4
133,0 mm	5.250 133,0	700 4825	15,145 67395	0.16 4,1	2 - 16 X 82,5	6.69 170	9.60 244	2.07 53	7.4 3,4
139,7 mm	5.500 139,7	700 4825	16,625 73980	0.16 4,1	2 - 16 X 82,5	6.94 176	9.82 249	2.07 53	7.6 3,4
6 150	6.625 168,3	700 4825	24,130 107380	0.16 4,1	2 - 5/8 X 3 1/4	8.26 210	10.83 275	2.07 53	8.3 3,8
159,0 mm	6.250 159,0	700 4825	21,465 95520	0.16 4,1	2 - 16 X 82,5	7.84 199	10.54 268	2.07 53	9.2 4,2
165,1 mm	6.500 165,1	700 4825	23,225 103305	0.16 4,1	2 - 5/8 X 3 1/4	8.13 207	10.84 275	2.07 53	8.3 3,8

Table continued on page 2.

\* # @ Refer to notes on page 2.

**VICTAULIC® IS AN ISO 9001 CERTIFIED COMPANY**

**Victaulic Company of America**  
Phone: 1-800-PICK-VIC (1-800-742-5842)  
Fax: 610-250-8817  
e-mail: pickvic@victaulic.com

**Victaulic Company of Canada**  
Phone: 416-675-5575  
Fax: 416-675-5565  
e-mail: viccanada@victaulic.com

**Victaulic Europe**  
Phone: 32-9-381-1500  
Fax: 32-9-380-4438  
e-mail: viceuro@victaulic.be

**Victaulic America Latina**  
Phone: 610-559-3300  
Fax: 610-559-3608  
e-mail: vical@victaulic.com

**Victaulic Asia Pacific**  
Phone: 65-235-3035  
Fax: 65-235-0535  
e-mail: vicap@victaulic.com

## DIMENSIONS

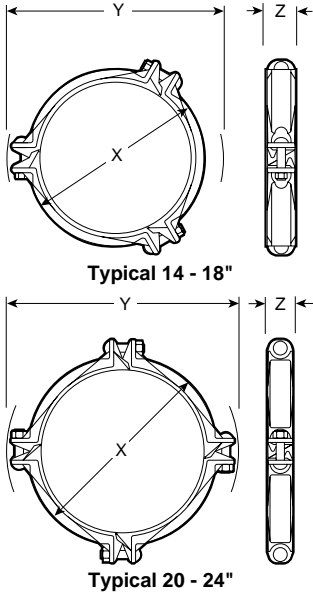

Nominal Size Inches mm	Diameter Inches mm	Max. Work Press. PSI* kPa	Max. End Load Lbs.* N	Allow. Pipe End # Sep. In. mm	@ Bolt/Nut No. - Size Inches mm	Dimensions Inches/millimeters			Aprx. Wgt. Each Lbs. kg
						X	Y	Z	
8 200	8.625 219.1	600 4130	35,000 155750	0.19 4.8	2 - 3/4 X 4 1/4	10.54 268	13.74 349	2.51 64	15.1 6.8
10 250	10.750 273.0	500 3450	45,400 202030	0.13 3.3	2 - 7/8 X 6 1/2	12.86 327	16.98 431	2.56 65	23.5 10.7
12 300	12.750 323.9	400 2750	51,000 226950	0.13 3.3	2 - 7/8 X 6 1/2	14.86 377	18.88 480	2.56 65	28.2 12.8
14 350	14.000 355.6	250 1725	38,485 171180	0.13 3.2	3 - 7/8 X 5	16.06 408	19.89 505	2.87 73	32.8 14.9
16 400	16.000 406.4	250 1725	50,265 223580	0.13 3.2	3 - 7/8 X 5	18.39 467	21.84 555	2.87 73	41.2 18.7
18 450	18.000 457.0	250 1725	63,615 282970	0.13 3.2	3 - 7/8 X 5	20.68 525	23.89 607	3.00 76	54.2 24.6
20 500	20.000 508.0	250 1725	78,540 349345	0.13 3.2	4 - 1 X 5	22.93 582	27.47 698	3.00 76	67.2 30.5
24 600	24.000 610.0	250 1725	113,000 502850	0.09 2.3	4 - 1 X 5	27.05 687	31.61 803	3.06 78	76.2 34.6

§ Couplings 8, 10, 12" (200, 250, 300 mm) sizes available to JIS standard. Refer to section 06.17 for details.

\* # @ See notes below.

## TORQUE REQUIREMENTS

Nominal Size inches/mm	Diameter Inches/mm	Recommended Torque ft. lbs./N•m
14, 16 & 18 350, 400, 450	14.000, 16.000, 18.000 355.6, 406.4 & 457.0	250 340
20 & 24 500, 600	20.000, 24.000 508.0, 610.0	300 407

## MATERIAL SPECIFICATIONS

**Housing:** Ductile iron conforming to ASTM A-395, grade 65-45-15, and ASTM A-536, grade 65-45-12.

**Housing Coating:** Orange enamel.

□ **Optional:** Hot dipped galvanized and others.

**Coupling Gasket:** (specify choice\*)

□ **Grade "E" EPDM Vic-Plus Gasket System**  
EPDM (Green color code).  
Temperature range -30°F to +230°F (-34°C to +110°C).  
Recommended for cold and hot water service within the specified temperature range plus a variety of dilute acids,

oil-free air and many chemical services. UL classified in accordance with ANSI/NSF 61 for cold +86°F (+30°C) and hot +180°F (+82°C) potable water service. NOT RECOMMENDED FOR PETROLEUM SERVICES.

□ **Grade "T" nitrile Vic-Plus Gasket System**  
Nitrile (Orange color code).  
Temperature range -20°F to +180°F (-29°C to +82°C).  
Recommended for petroleum products, air with oil vapors, vegetable and mineral oils within the specified temperature range. Not recommended for hot water services over +150°F (+66°C)

or for hot dry air over +140°F (+60°C).

\*Services listed are General Service Recommendations only. It should be noted that there are services for which these gaskets are not recommended. Reference should always be made to the latest Victaulic Gasket Selection Guide for specific gasket service recommendations and for a listing of services which are not recommended.

**Bolts/Nuts:** Heat treated carbon steel, track-head conforming to physical properties of ASTM A-183, minimum tensile 110,000 PSI (758340 kPa), zinc electroplated per ASTM B-633.

### NOTES

\* Working Pressure and End Load are total, from all internal and external loads, based on standard weight (ANSI) steel pipe, standard **roll** or **cut** grooved in accordance with Victaulic® specifications. Contact Victaulic for performance on other pipe.

WARNING: FOR ONE TIME FIELD TEST ONLY, the Maximum Joint Working Pressure may be increased to 1½ times the figures shown.

# For field installation only on roll grooved pipe or cut grooved pipe. Zero-Flex Style 07 couplings are essentially rigid and do not permit expansion/contraction.

@ Number of bolts required equals number of housing segments.

Metric thread size bolts are available (color coded gold) for all coupling sizes upon request. Contact Victaulic for details.

Style 07 couplings must **not** be used to join PVC pipe.

WARNING: Piping systems must always be depressurized and drained before attempting disassembly and removal of any Victaulic piping products.

This product shall be manufactured by Victaulic Company. All products shall be installed in accordance with current Victaulic installation/assembly instructions. Victaulic reserves the right to change product specifications, designs and standard equipment without notice and without incurring obligations.